

UFRO 5722 NOISE SOURCE USER'S MANUAL

Dave Typinski, April, 2020

Description

The UFRO 5722 Noise Source is based on two Sylvania 5722 vacuum tube noise diodes operating in parallel. The unit has been modified by AJ4CO to eliminate the plate current sensing resistor and remote power supply controls as the original power supplies have been replaced with supplies that include accurate voltage and current meters. The circuit is much like that recommended by Sylvania. A schematic and tube tech data are included in this manual.

The assembly is built on one 3U (5¼" tall) 19" rack panel and requires two power sources:

Filament supply: 5.2 VDC at 3.1 A

Plate supply: 150 VDC at 70 mA

As installed at AJ4CO Observatory, the filament supply is a TTi PL155 power supply and the plate voltage is provided by a TTi PLH250 power supply.

In the Summer of 2012, the noise generator was salvaged from the Dixie Radio Observatory. In the Spring of 2013, it was found that the 5 VDC supply being used for the filament circuit could no longer deliver the required current—about 5 volts at 3.1 amps. In lieu of another 5 VDC supply, the noise generator panel was modified to include a 6.3 volt filament transformer driven by a small variac. That is, the filaments were then fed with ~ 5 VAC.

In June 2017, it was noticed that line voltage variations were causing a +/- 2 mA random oscillation in plate current. This is equivalent to +/- 0.12 dB in terms of noise power output. It was decided that a 0.25 dB uncertainty range was too large.

In May, 2018, the AC filament power circuit elements were removed and replaced by the TTi low voltage DC supply in May, 2018. The plate current sensing resistor was also removed, as the plate current reading on the new TTi plate supply was observed to be within 0.01 mA of that shown on a freshly-calibrated HP 34401A DVM connected in series. Ref circuit diagram Rev C.

In April, 2020, the 4700 pF output coupling cap was moved to the filament center tap of one of the tubes and the RF output was straight from the plates. Ref circuit diagram Rev D. A 0.1 μF coupling cap was added between the plate and RF output. Ref circuit diagram Rev E. The noise temperature output of circuit revisions C, D, and E were measured; no appreciable difference was observed. The noise generator was left in the Rev E state.

With 70 mA of plate current, the noise output is 20,600 K into a 50 ohm load.

Operation

Start up:

- 1) Connect power supplies, **note proper polarity: plate supply positive goes to ground.**
- 2) Feed 3.5 VDC to the filament circuit to put the tubes in standby mode. Best practice for tube type equipment is to always turn on the filaments before applying plate voltage.
- 3) Feed 150 VDC to the plate circuit.
- 4) Increase the filament voltage until the plate current reads about 67 mA. Use the fine voltage control to increase the filament voltage until the plate current reads 70 mA.
- 5) Allow a 10-minute stabilization period during which time the plate current will slowly drop a few mA as the tubes reach thermal equilibrium. Use the fine voltage control on the filament supply to keep the plate current near 70 mA.
- 6) After the 10-minute stabilization period, measurements of the RF noise output may be made. Continue using the fine voltage control on the filament supply to keep the plate current between 69.9 and 70.1 mA. This is not difficult after that stabilization period. Typical stable values are:

Filament: 5.15 VDC @ 3.078 A \pm 10 mA

Plate: 150 VDC @ 70.0 \pm 0.1 mA

NOTE: While the Sylvania manual recommends keeping the maximum on period in a 50% duty cycle to no more than 5 minutes, the unit has been operated for up to an hour at a time with no apparent detrimental effects. However, it is possible that this may shorten tube life, so extended periods of operation should be avoided when possible. The Sylvania manual indicates a tube life of about 100 hours when the filaments are operated at 5.15 volts.

Shut down:

- 1) Turn off the DC plate supply.
- 2) Turn the filament supply voltage down to zero and then turn it off.



Figure 1 – 5722 diode noise generator, two tubes in parallel.

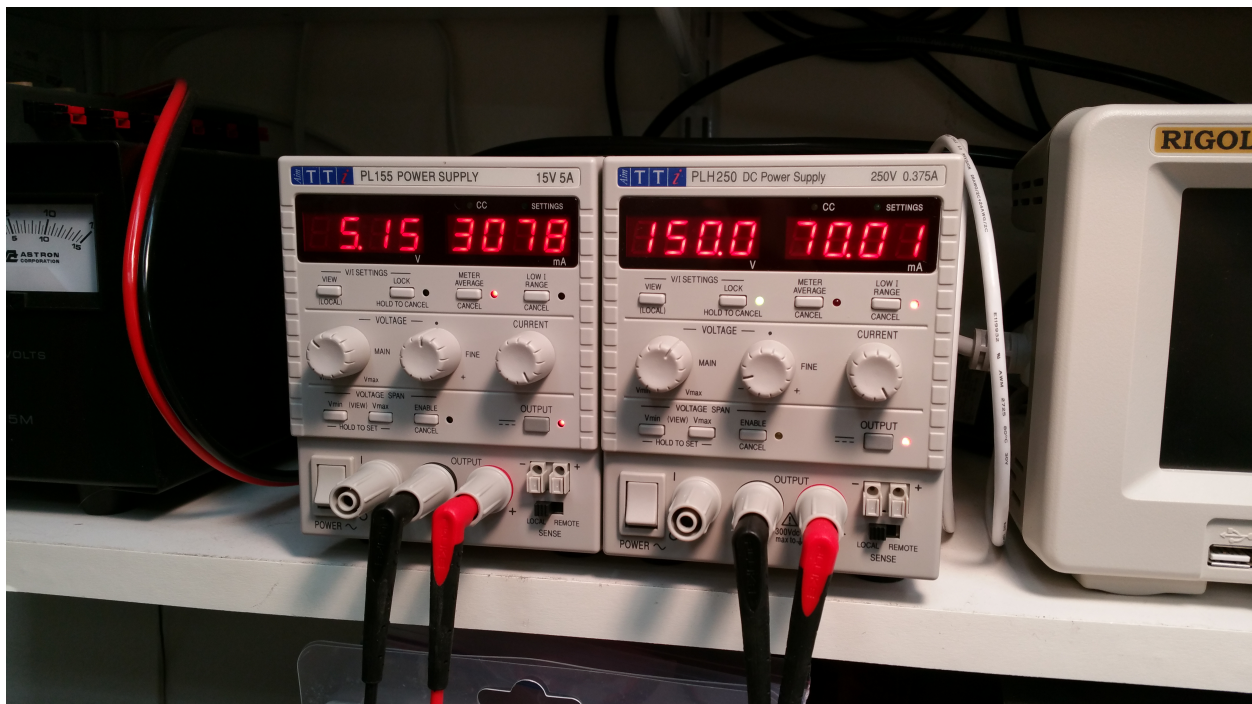

Figure 2 – Power supplies showing typical voltages and currents.

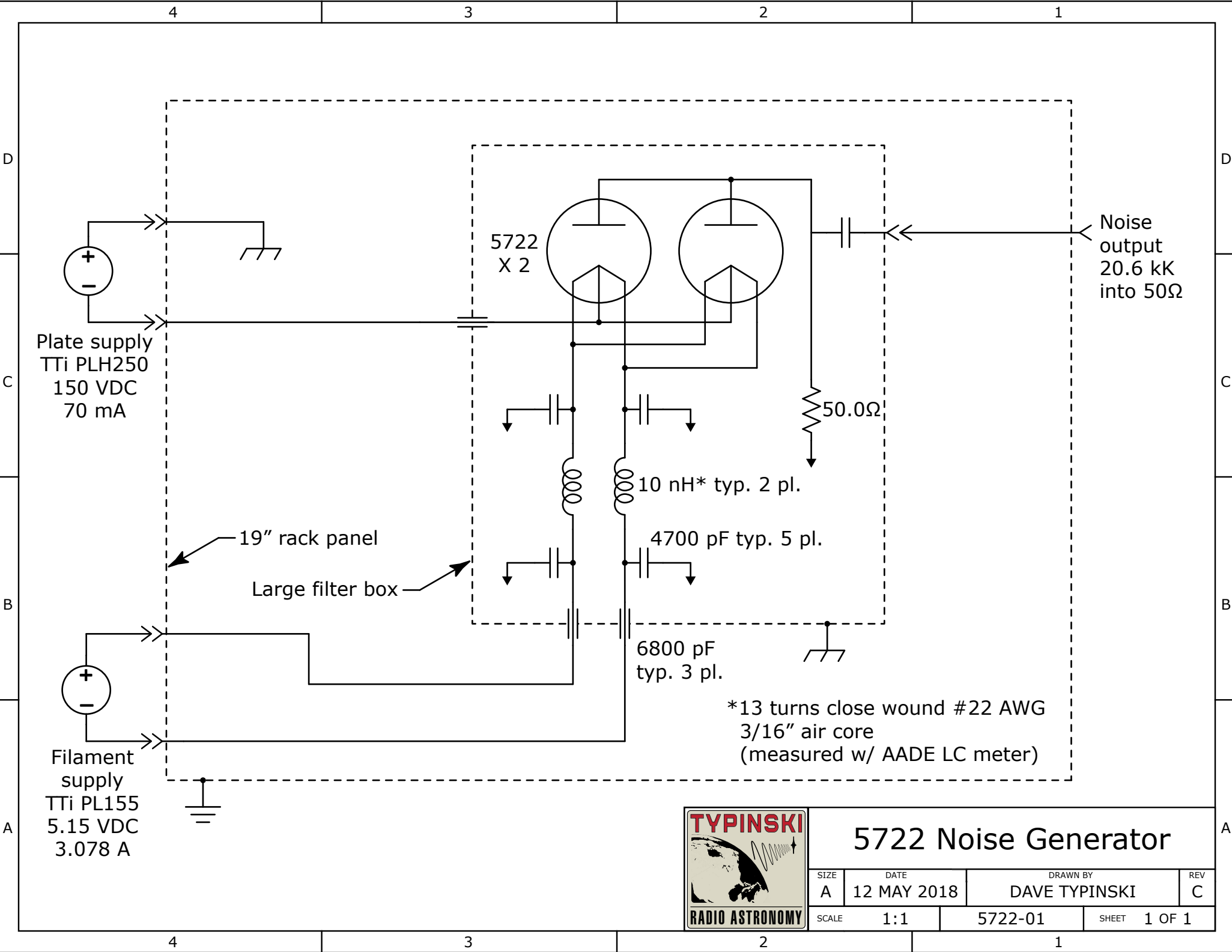

Plate supply
TTi PLH250
150 VDC
70 mA

Filament supply
TTi PL155
5.15 VDC
3.078 A

19" rack panel

Large filter box

5722
X 2

10 nH* typ. 2 pl.

4700 pF typ. 5 pl.

6800 pF
typ. 3 pl.

50.0Ω

Noise output
20.6 kK
into 50Ω

*13 turns close wound #22 AWG
3/16" air core
(measured w/ AADE LC meter)



5722 Noise Generator

SIZE A	DATE 12 MAY 2018	DRAWN BY DAVE TYPINSKI	REV C
SCALE 1:1	5722-01	SHEET 1 OF 1	

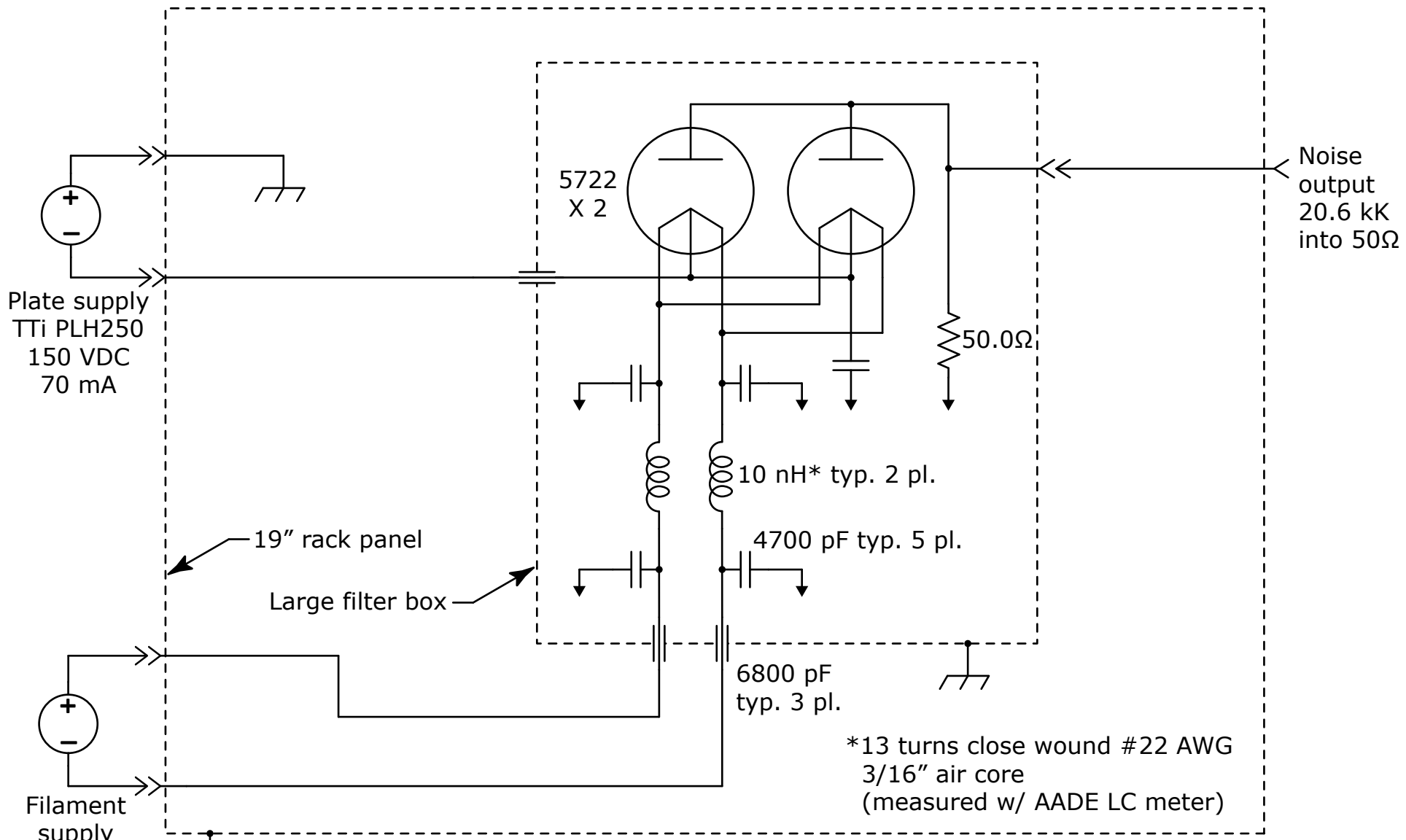

5722 Noise Generator

SIZE A	DATE 11 APR 2020	DRAWN BY DAVE TYPINSKI	REV D
SCALE 1:1	5722-01	SHEET 1 OF 1	

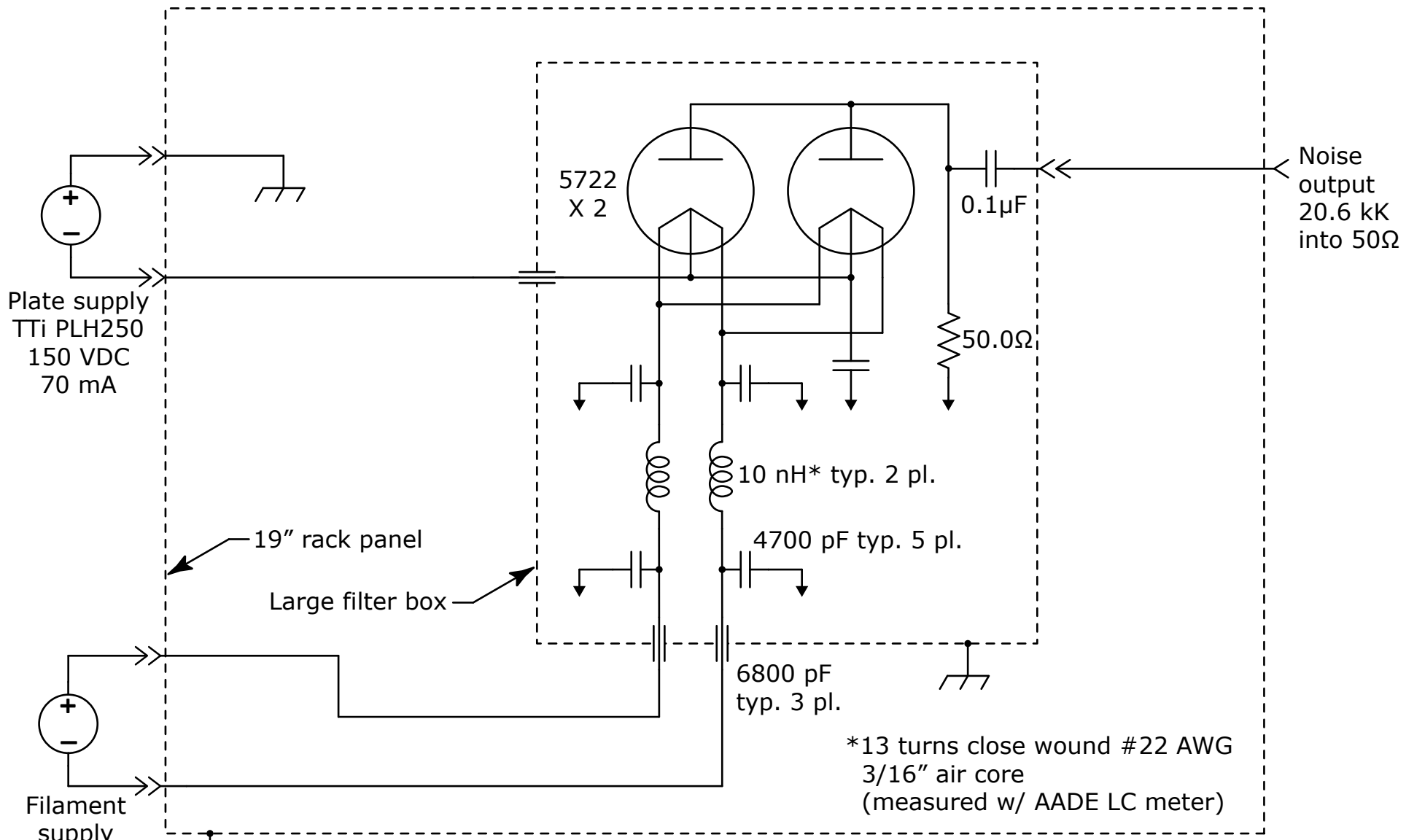

5722 Noise Generator

SIZE A	DATE 11 APR 2020	DRAWN BY DAVE TYPINSKI	REV E
SCALE 1:1	5722-01	SHEET 1 OF 1	

UFRO 5722 Noise Diode Output Temperature Calculation

ref Francisco Reyes's notes

T0	290	K
e	1.602E-19	C
I	70.0	mA
R	50.0	Ω
k	1.381E-23	J/K
eR/2K	290007.2411	
T_gen	20,591	K

$$T_{gen} = T_0 + \frac{eIR}{2k}$$

$$T_{gen} = 290 + 290I = 290(1+I) \text{ where } I \text{ is in mA}$$

Noise diodes 5722 calibrator

(Translation of Appendix A of F. Reyes Univ. of Chile thesis "Radiotelescopio en 45 MHz para Fuentes Extragalacticas, 1977)

In order to determine the absolute power received by a radio telescope it is necessary to have of a source that provide a signal of a known power, so it can be used as a calibrator. Since the signal received by the antenna has the characteristic of noise, it is required that the calibrator has the same characteristics.

A resistor at the absolute temperature T generates a noise power W that can be calculated by

$$W = kT\Delta v \quad (1)$$

Where k is the Boltzmann constant and Δv is the bandwidth

In radio astronomy and in particular at low frequencies the antenna temperatures are of the order of several thousand K. This makes impossible to obtain a source of noise of the required power from the noise produced by a resistor.

For the frequency range of 1 to 1000 MHz, it is accepted as a standard noise source, the saturated diodes limited by temperature.

The quadratic mean value of the noise current i_n^2 for these diodes is given by the relationship

$$i_n^2 = 2eI\Delta v \quad (2)$$

Where e is the charge of the electron ($1,6 \cdot 10^{-19}$ coulombs) and I is the plate DC current of the diode

These diodes are essentially a source of noise current. It is necessary to define the noise power delivered by the diodes by defining the impedance over which the noise current circulate. Figure 1 is a simplified schematic of the circuit of a noise diode.

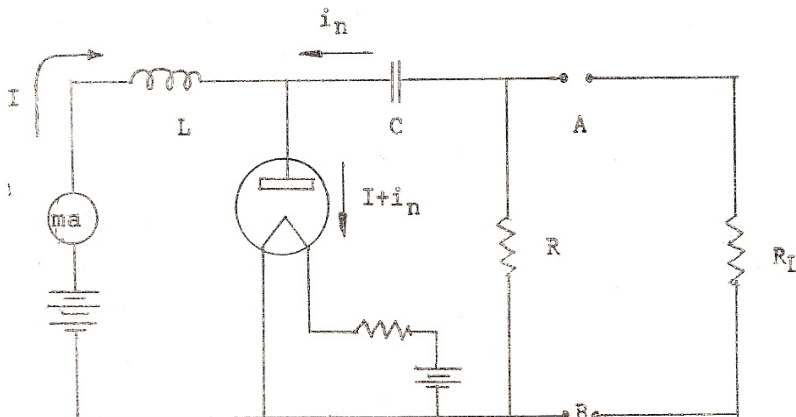

Figure 1. Simplified schematic of the circuit of a noise diode

R_L is the load resistor (of value equal to R), R is the resistor that define the power delivered by the diode, C a capacitor to isolate R from the DC plate voltage and L is an inductance to keep the noise power from reaching the DC plate voltage source.

The noise power available at the terminals AB is

$$W = (\frac{1}{2}i_n)^2 R \quad (3)$$

(3) The power can be expressed as function of temperature by combining equations (1) and

$$kT\Delta v = (\frac{1}{2}i_n)^2 R$$

Rearranging this equation and substituting by equation (2) we get

$$T = eIR/2k$$

To this noise temperature T one has to add the contribution of noise due to the ambient temperature T_o of the resistor R .

The equation becomes

$$T_g = T_o + eIR/2k \quad (4)$$

This equation shows that it is possible to determine the noise temperature of the diodes by measuring I , the DC plate current.

Substituting in equation (4) the values for $e = 1.6 \cdot 10^{-19}$ Coulombs, $k = 1.38 \cdot 10^{-23}$ Joule/K, $T_o = 290$ K, $R = 75$ ohms and expressing the current I in milliamps,

$$T = 434.78 I + 290 \text{ (in K)} \quad (5)$$

One of the diodes commonly used is the 5722. Some of the parameters of this diode are:

- Maximum plate current = 35 ma
- Plate voltage = 200 v
- Output capacitance = 2.2 pf
- Filament voltage = 6.3 v
- Filament current = 1.5 amps

Most calibrator used at radio observatories in the past make use of two 5722 diodes. Two diodes provides up to 70 ma DC current, which correspond to a noise temperature of 30,000 K. This standard calibrator can be used to calibrate other source noise such as the noisy amplifier HP 461 which can provide up to 60 million K of noise temperature which makes them useful for calibrating low frequency emission from Jupiter and the Sun.

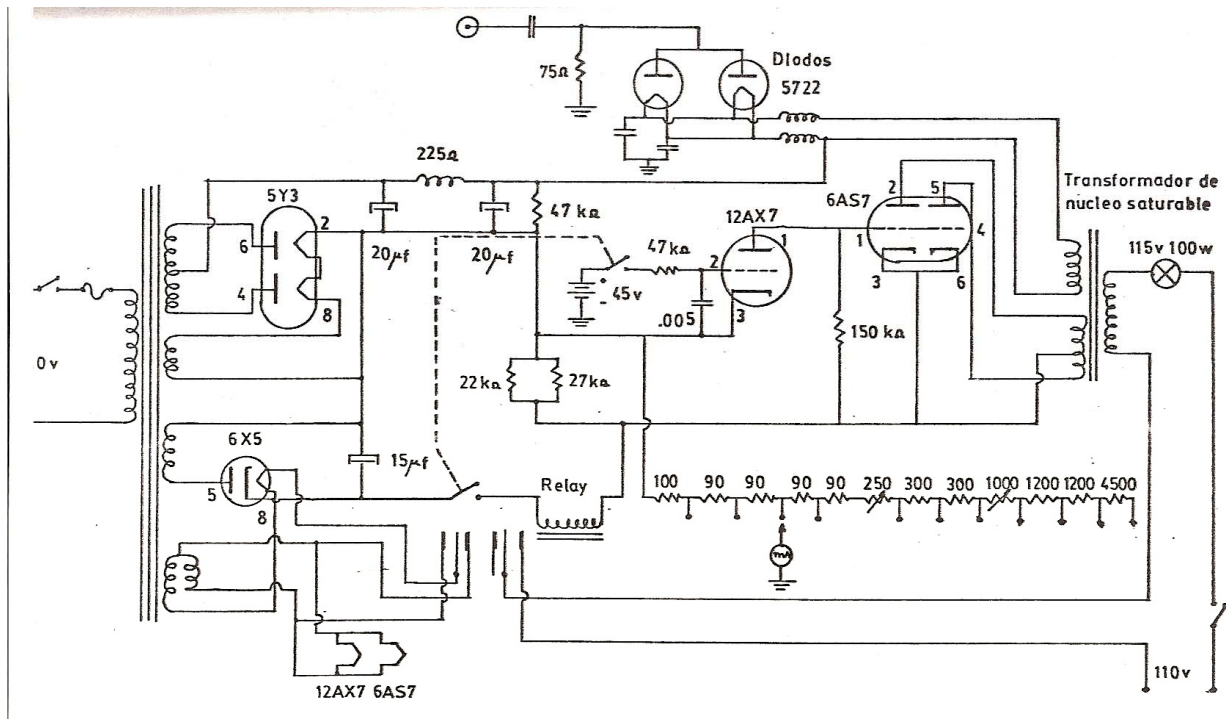

Figure 2. Schematic of 5722 noise diodes and power supply

References

R.N. Bracewell, Radio Astronomy Techniques. In Handbuch Der Physik, Volume LIV, pages 53-55

J.D. Kraus, Radio Astronomy, chapter 7 (by Martti E. Tiuri) pages 284-286

FR

07/19/2012

Sylvania TYPE 5722

NOISE GENERATING DIODE

RATINGS AND CHARACTERISTICS

Maximum Filament Voltage	5.5	Volts
Minimum Filament Voltage	2.0	Volts
Filament Current at 4.9 Volts	1.6	Amperes
Maximum DC Plate Voltage	200	Volts
Maximum Plate Current	35	Ma.
Maximum Plate Dissipation		
Continuous Service	3.5	Watts
Intermittent Service	5.0	Watts
Maximum On Period in 50% Duty Cycle	5	Min.
Direct Interelectrode Capacitances:**		
Plate to Filament	1.5	μf

* Horizontal operation permitted if Pins 1 and 2 are in vertical plane.

** With no external shield.

TYPICAL OPERATING CONDITIONS

Plate Voltage	150	Volts
Filament Voltage	Adjust to give desired Plate Current or Noise Output	

CIRCUIT APPLICATION

Sylvania Type 5722 is a tungsten filament diode designed for use as a noise generator at frequencies up to 400 or 500 mc. The filament center tap allows better RF grounding of the filament when used in the recommended circuit shown on a following page.

Since the tube has a tungsten filament the "shot effect" may be used as a standard noise source if sufficient plate voltage is applied to obtain saturation. The noise factor (NF) may be obtained from the equation $NF = 20 IR$ where R is the total generator resistance and I is the diode plate current in amperes. To convert to decibels $NF_{db} = 10 \log_{10} 20 IR$.

In use, the diode is coupled to the input of the amplifier under test and the filament voltage is increased until the noise output power is double that read without the diode. From the plate current reading and the generator resistance the noise factor can be calculated. Additional construction details may be obtained from the article "How Sensitive is Your Receiver", by Byron Goodman in the September 1947 issue of Q.S.T. and also "Coaxial Noise Diode" by H. Johnson, RCA Review, March, 1947, Volume VIII, No. 1.

The useful life is dependent on the operating voltages since the usual causes of failure are burnout or vaporization of the tungsten filament. A curve is given on a following page which shows this relationship.

PHYSICAL SPECIFICATIONS

Style	Miniature
Bulb	T 5 1/2
Diameter	3/4" Max.
Seated Height	1 7/8" Max.
Overall Length	2 1/8" Max.
Mounting	Vertical*

BASE PIN CONNECTIONS

Pin 1 - Plate
Pin 2 - No Connection
Pin 3 - Filament
Pin 4 - Filament
Pin 5 - No Connection
Pin 6 - Plate
Pin 7 - Filament Center

RMA Basing 5 CB

RECOMMENDED CIRCUIT

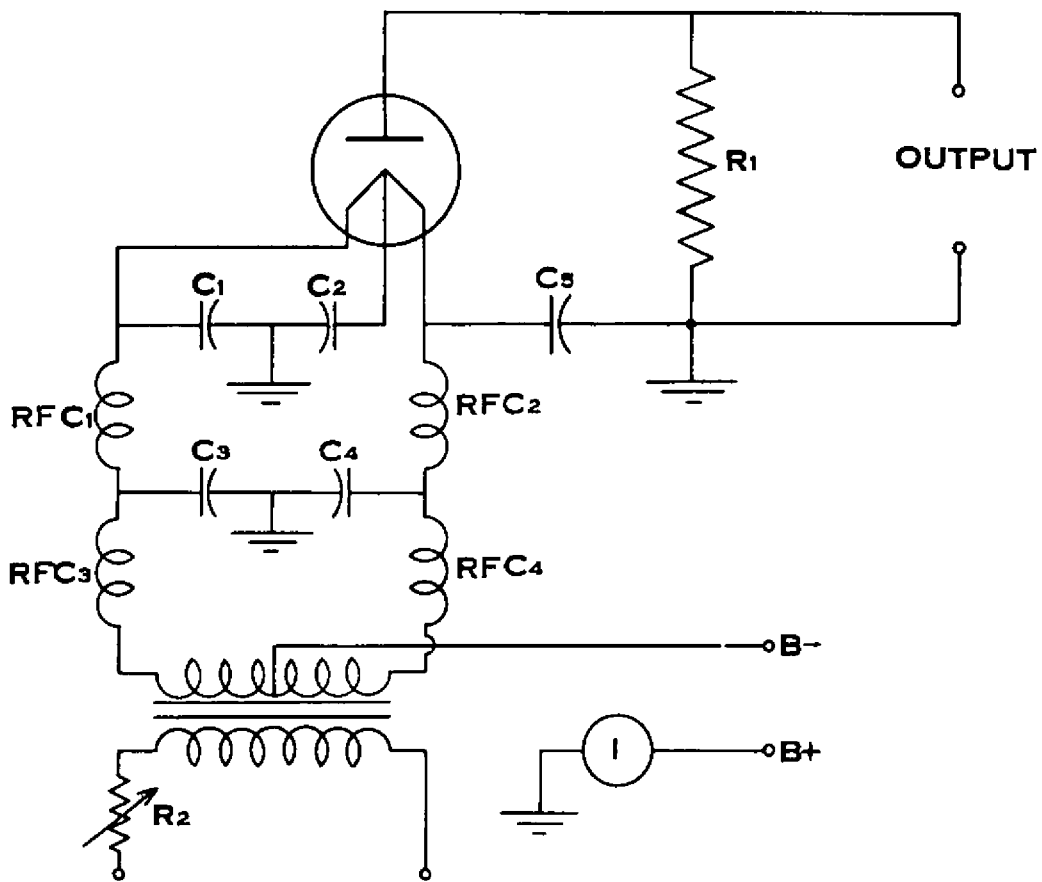

PARTS LIST

C ₁	}	500 μ f
C ₂		
C ₃		
C ₄		
C ₅		
RFC ₁	}	6 Turns #16 Enamel Wire on 3/16" Air Core
RFC ₂		
RFC ₃	}	30 Turns #16 Enamel Wire on 3/8" O.D., 1/4" I.D. Bakelite Coil Form With Powdered Iron Core
RFC ₄		
R ₁	50 to 300 Ohms as Required to Match Load	
R ₂	Filament Voltage Control	

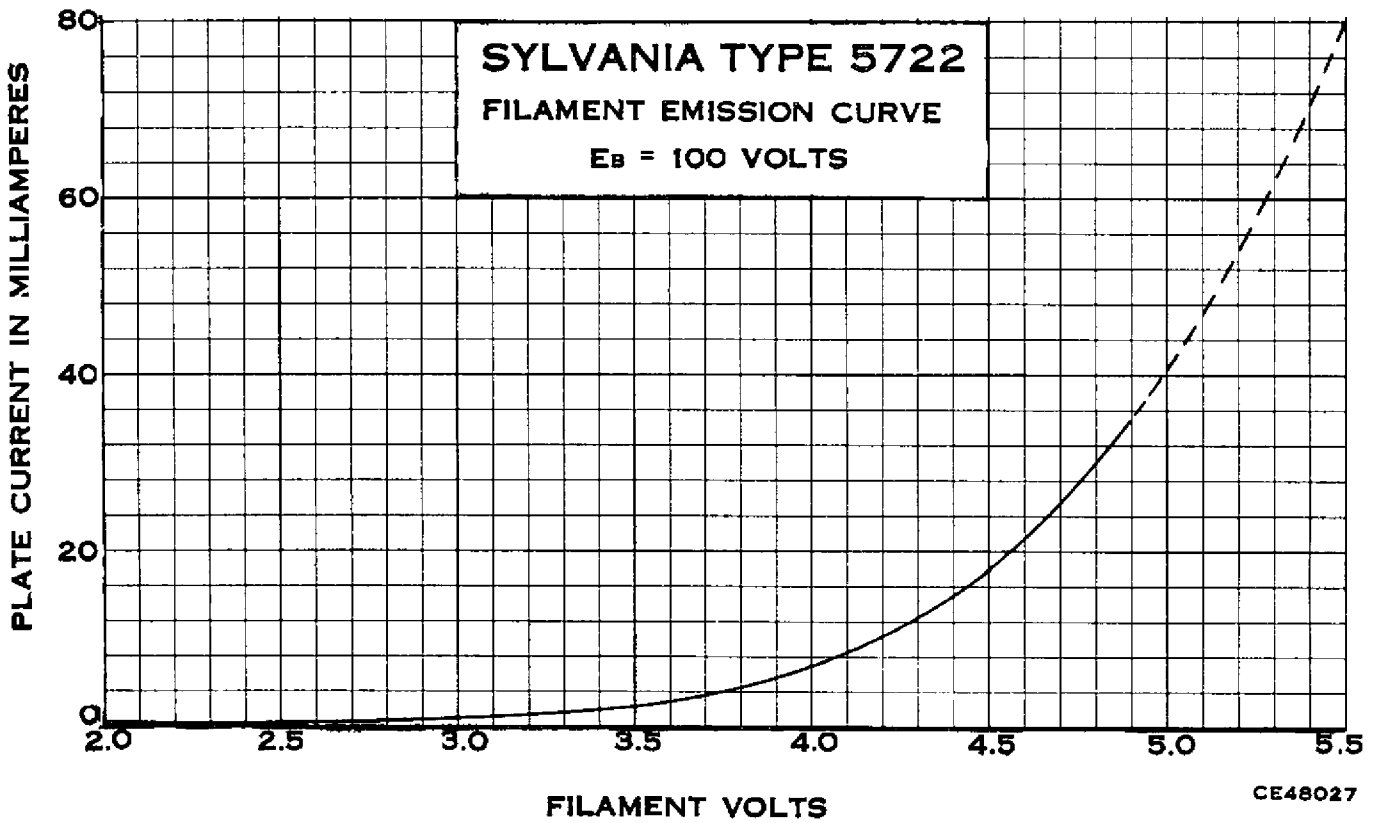
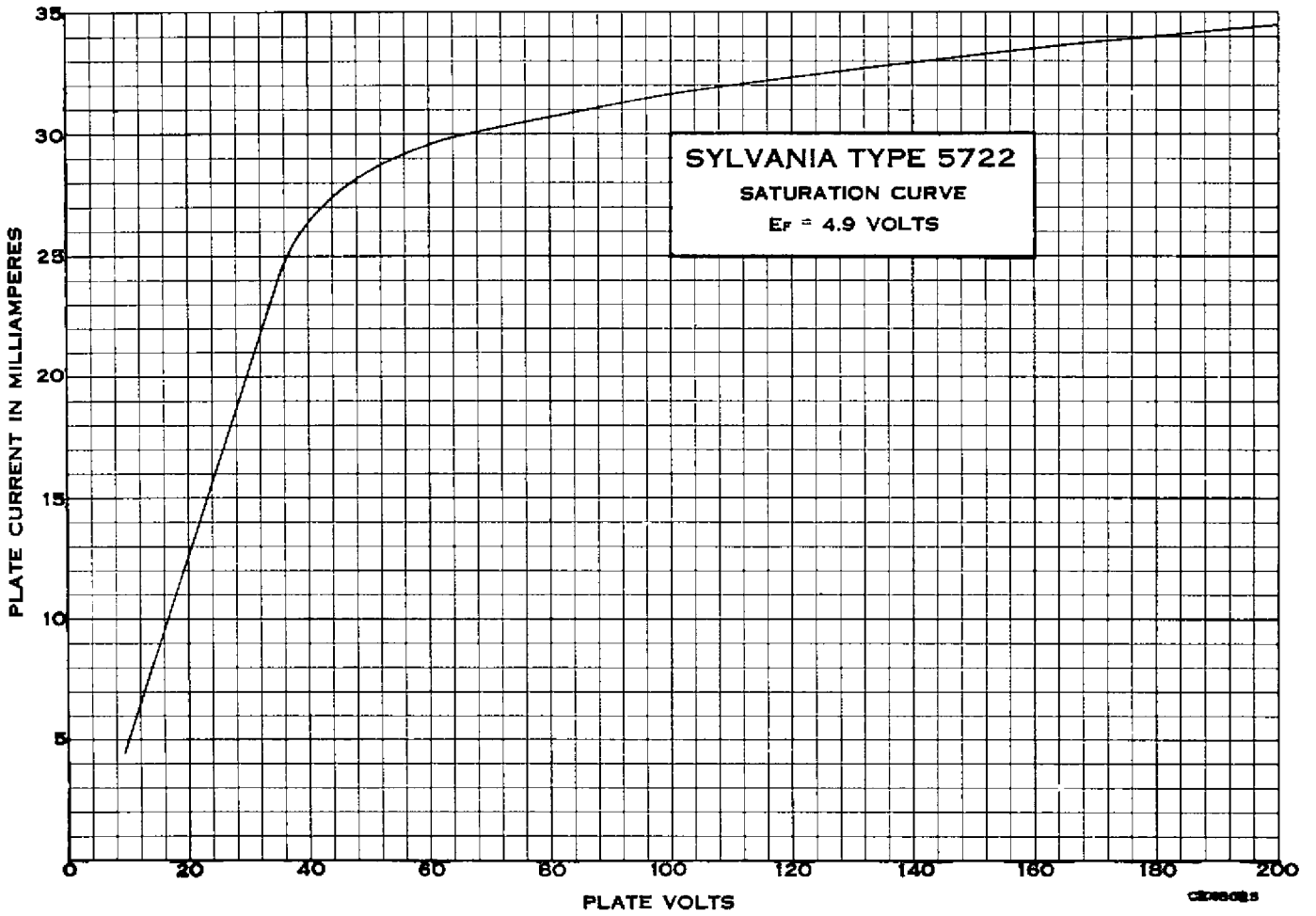

SYLVANIA TYPE 5722
LIFE EXPECTANCY VS FILAMENT VOLTS
E_B = 100 VOLTS
LIFE END POINT DETERMINED BY
40% REDUCTION IN FILAMENT DIAMETER

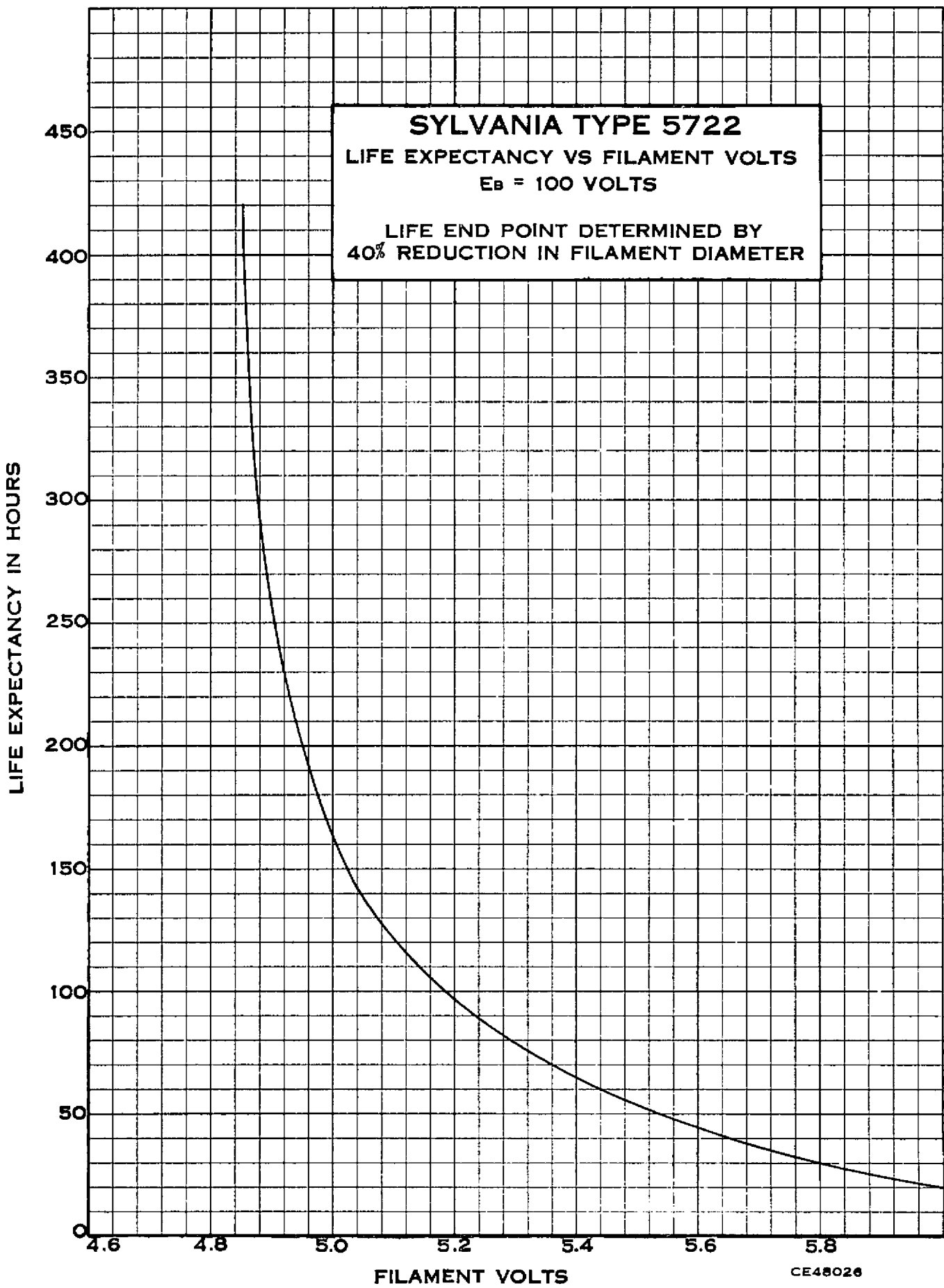



QUICK REFERENCE DATA

The Sylvania Type 5722 is a miniature tungsten filament diode intended for use as a noise generator. It is designed for operation at frequencies up to 400 or 500 mc.

MECHANICAL DATA

Bulb	T-5 1/2
Base	E7-1 Miniature Button 7-Pin
Outline	5-2
Basing	5CB
Cathode	Tungsten Filament
Mounting Position	Vertical, Base up or down Horizontal, Leads 3 and 4 in a vertical plane

ELECTRICAL DATA

DIRECT INTERELECTRODE CAPACITANCES (Unshielded)

Plate to Filament	1.5 μ f
-----------------------------	-------------

RATINGS (Absolute Values)

Filament Voltage	5.5 Volts Max.
	2.0 Volts Min.
Plate Voltage (dc)	200 Volts Max.
Plate Current	35 Ma Max.
Plate Dissipation	
Continuous Service	3.5 Watts Max.
Intermittent Service	5.0 Watts Max.
Maximum on Period in 50% Duty Cycle	5 Minutes

CHARACTERISTICS.

Filament Voltage ¹	4.9 Volts
Filament Current	1.6 Amps
Plate Voltage	150 Volts
Plate Current	30 Ma

NOTE:

1. In application, adjust E_p to obtain desired Plate Current or Noise Output.

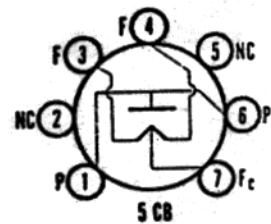
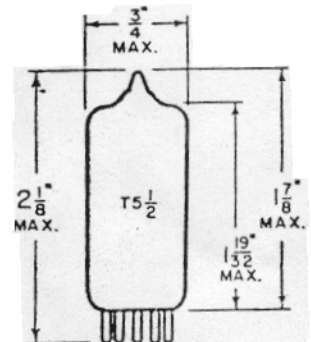

SYLVANIA ELECTRONIC TUBES

A Division of
SYLVANIA ELECTRIC PRODUCTS, Inc.

RECEIVING TUBE
OPERATIONS

EMPORIUM, PENNSYLVANIA

Prepared and Released By The
TECHNICAL PUBLICATIONS SECTION
EMPORIUM, PENNSYLVANIA

DECEMBER 1958

APPLICATION DATA

The Sylvania Type 5722 has a filament center tap which allows better RF grounding of the filament when used in the Recommended Circuit.

Since the tube has a tungsten filament the "shot effect" may be used as a standard noise source if sufficient plate voltage is applied to obtain saturation. The noise factor (NF) may be obtained from the equation $NF = 20 IR$ where R is the total generator resistance and I is the diode plate current in amperes. To convert to decibels $NF_{db} = 10 \text{ Log}_{10} 20 IR$.

In use, the diode is coupled to the input of the amplifier under test and the filament voltage is increased until the noise output power is double that read without the diode. From the plate current reading and the generator resistance the noise factor can be calculated. Additional construction details may be obtained from the article "Noise Generators and Measuring Techniques," by I. J. Melman in the May, June and July 1950 issues of Tele-Tech and also "Temperature-Limited Noise Diode Design," by R. W. Slinkman, in the October 1949 issue of The Sylvania Technologist.

The useful life is dependent on the operating voltages since the usual causes of failure are burnout or vaporization of the tungsten filament. A life expectancy curve is shown on a following page which illustrates this relationship.

CIRCUIT I

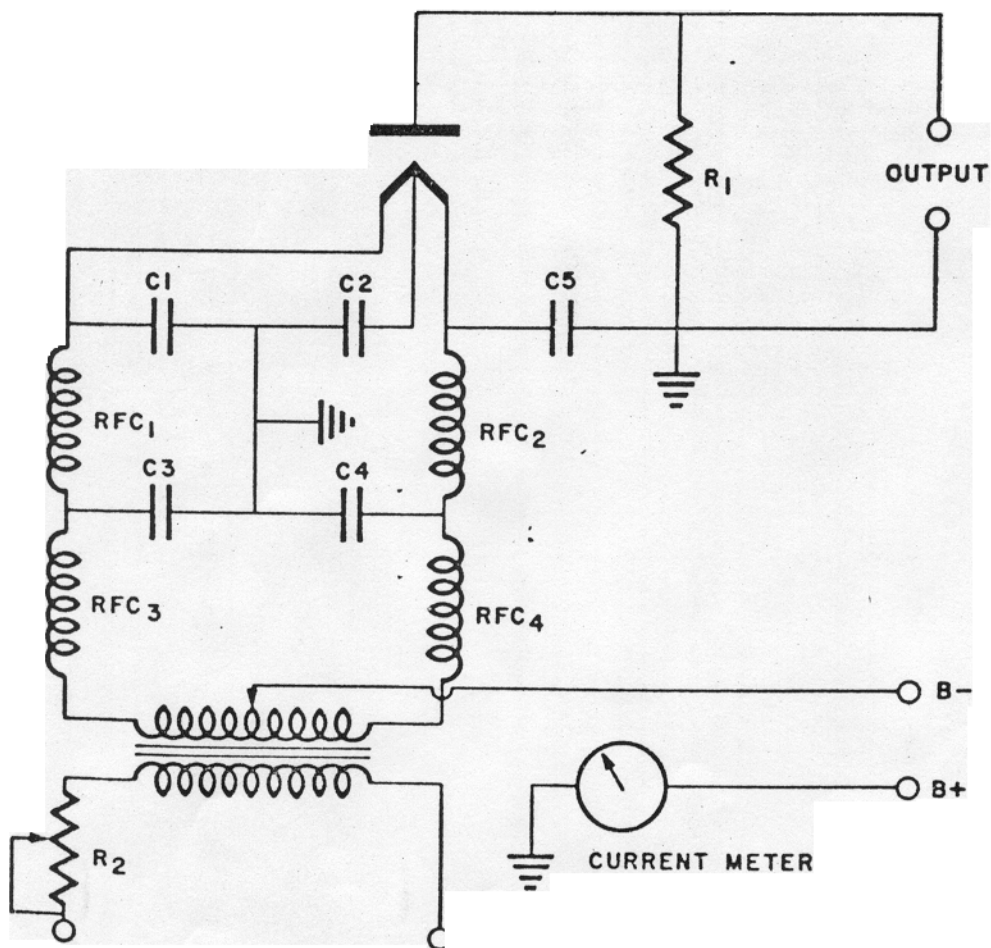

SATURATION CURVE

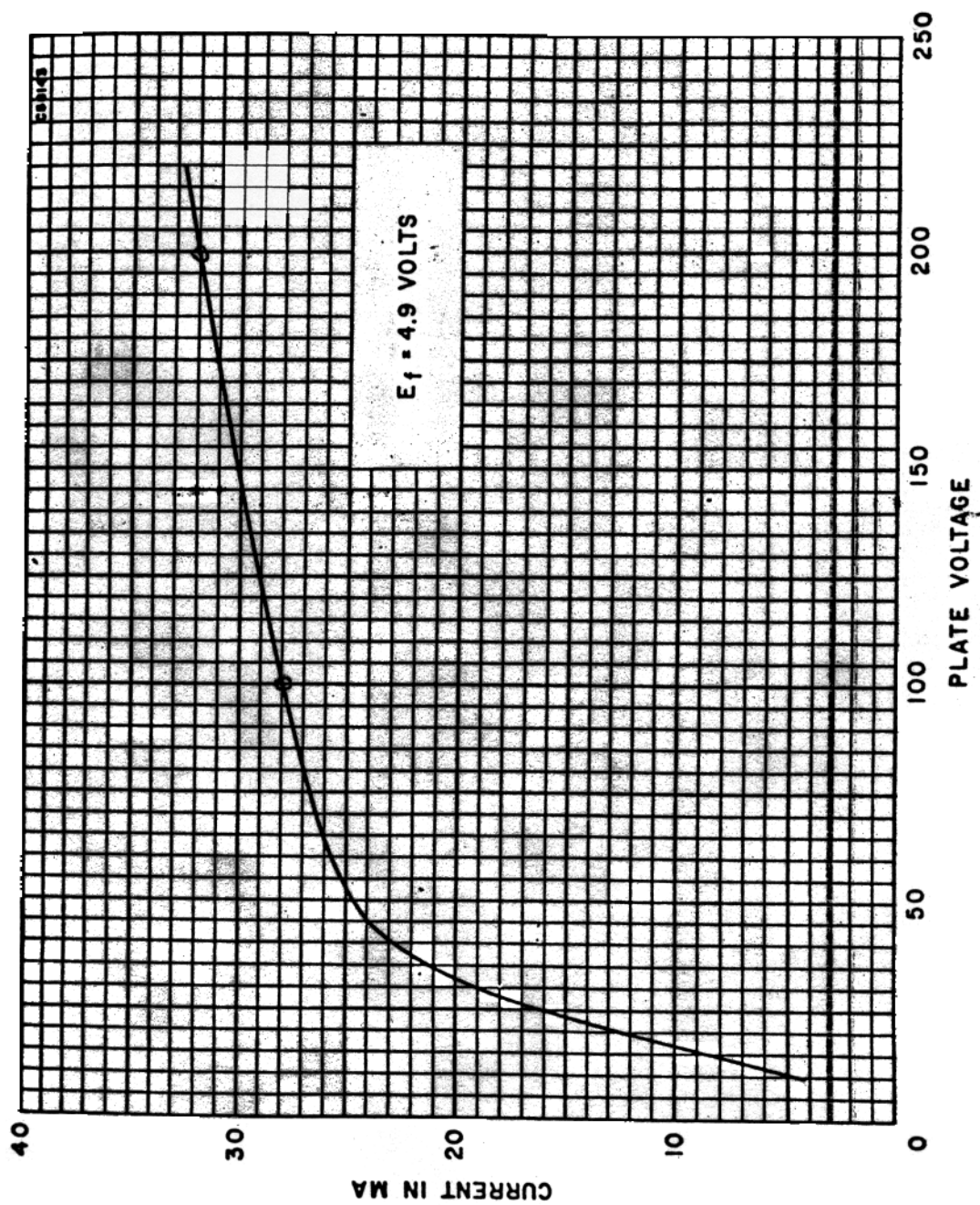

FILAMENT EMISSION CURVE

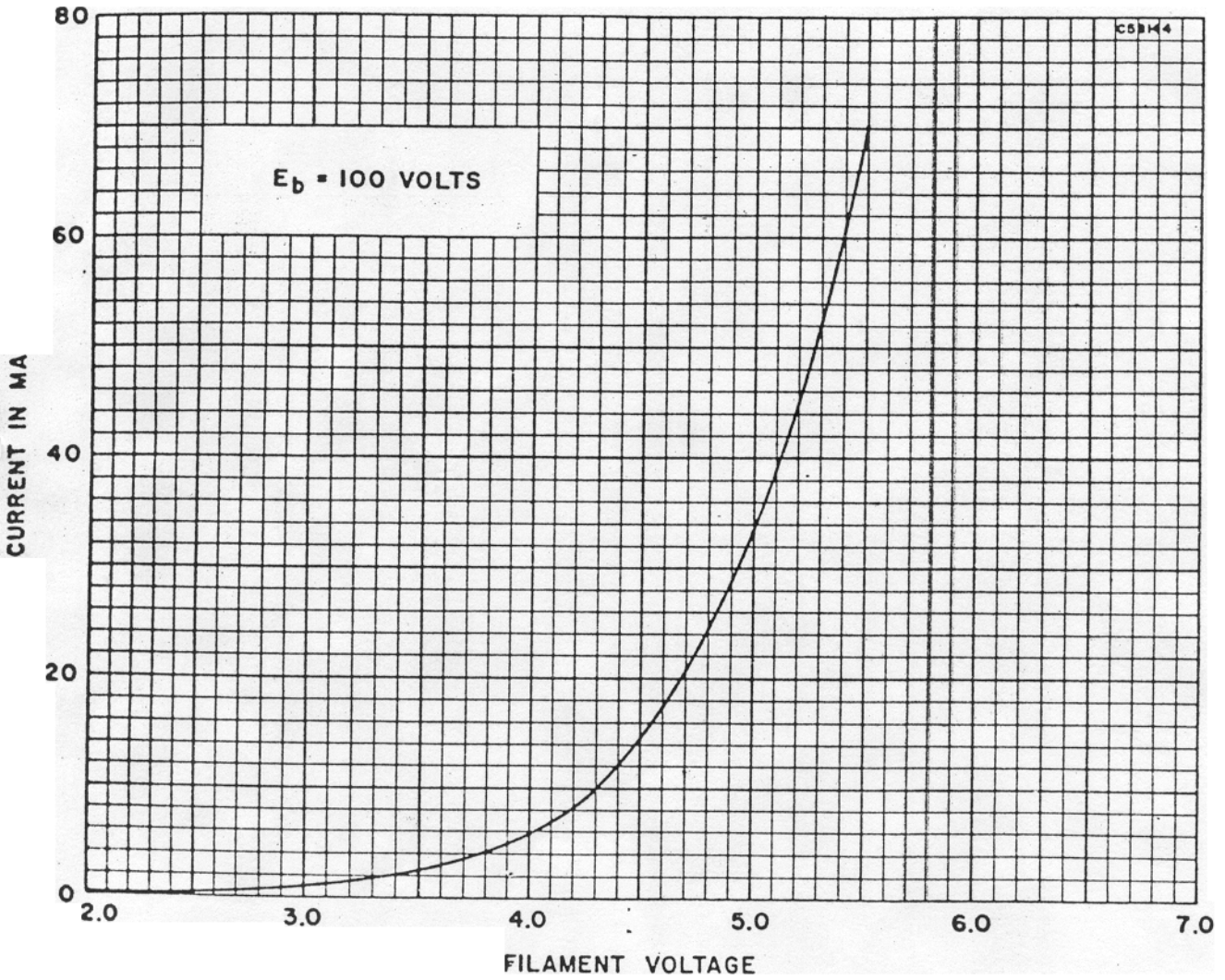

LIFE EXPECTANCY vs. FILAMENT VOLTS

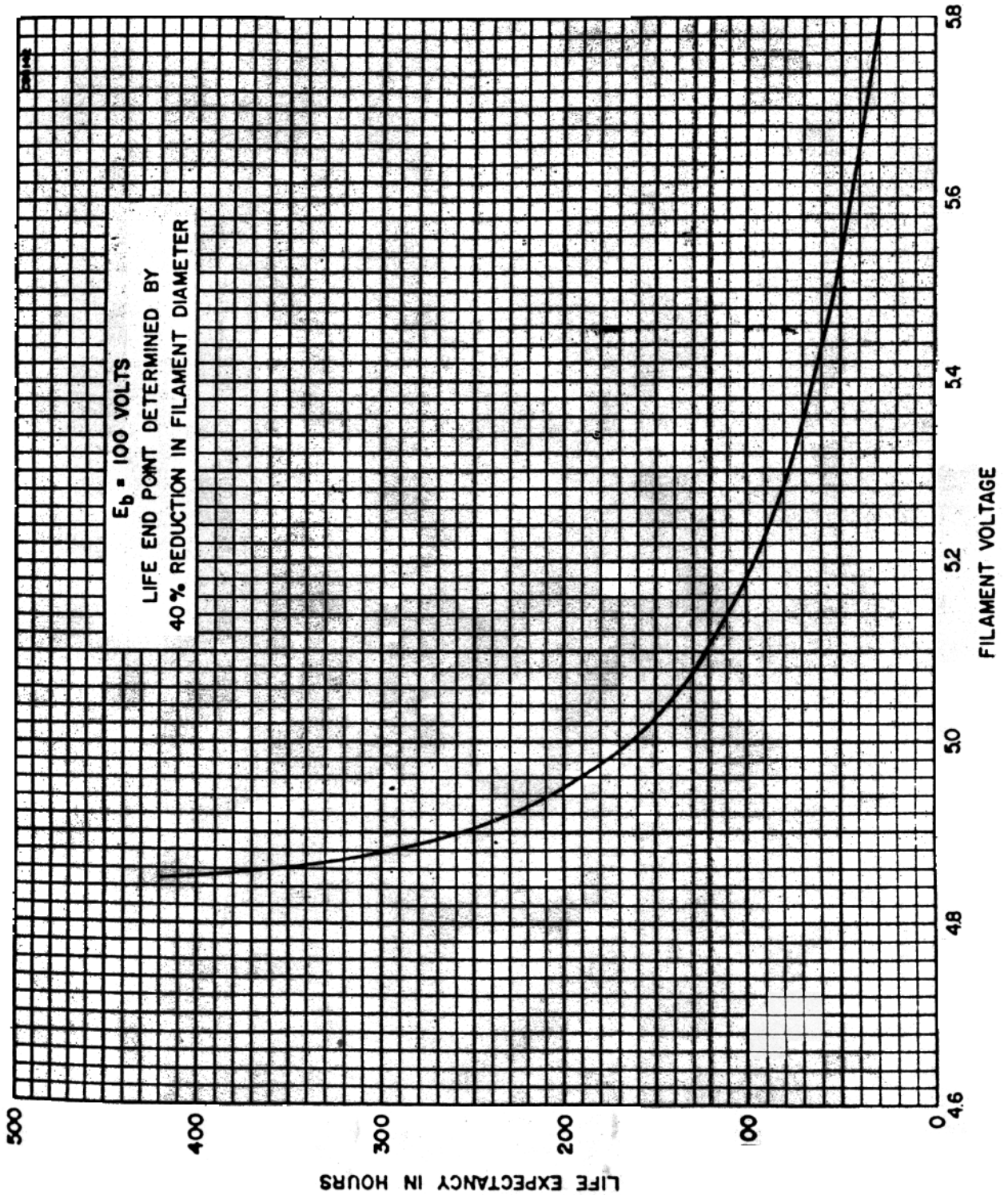

Sylvania Type 5722

NOISE GENERATING DIODE

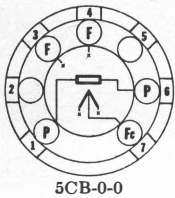

5CB-0-0

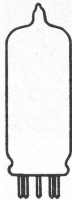

PHYSICAL SPECIFICATIONS

Base.....	Miniature Button 7 Pin
Bulb.....	T-5 $\frac{1}{2}$
Maximum Overall Length.....	2 $\frac{1}{8}$ "
Maximum Seated Height.....	1 $\frac{1}{8}$ "
Mounting Position.....	Vertical*

*Horizontal operation permitted if Pins 1 and 2 are in a vertical plane.

RATINGS

Maximum Filament Voltage.....	5.5 Volts
Minimum Filament Voltage.....	2.0 Volts
Filament Current at 4.9 Volts.....	1.6 Amperes
Maximum DC Plate Voltage.....	200 Volts
Maximum Plate Current.....	35 Ma.
Maximum Plate Dissipation	
Continuous Service.....	3.5 Watts
Intermittent Service.....	5.0 Watts
Maximum On Period in 50% Duty Cycle.....	5 Minutes

Direct Interelectrode Capacitances:*

Plate to Filament.....	1.5 μ f.
------------------------	--------------

*With no external shield.

TYPICAL OPERATION

Sylvania Type 5722 is a tungsten filament diode designed for use as a noise generator at frequencies up to 400 or 500 mc. The filament center tap allows better RF grounding of the filament when used in the recommended circuit shown on a following page.

Since the tube has a tungsten filament the "shot effect" may be used as a standard noise source if sufficient plate voltage is applied to obtain saturation. The noise factor (NF) may be obtained from the equation $NF = 20 IR$ where R is the total generator resistance and I is the diode plate current in amperes. To convert to decibels $NF_{db} = 10 \text{Log}_{10} 20 IR$.

In use, the diode is coupled to the input of the amplifier under test and the filament voltage is increased until the noise output power is double that read without the diode. From the plate current reading and the generator resistance the noise factor can be calculated. Additional construction details may be obtained from the article "How Sensitive is Your Receiver," by Byron Goodman in the September 1947 issue of Q.S.T. and also "Coaxial Noise Diode" by H. Johnson, RCA Review, March 1947, Volume VIII, No. 1.

The useful life is dependent on the operating voltages since the usual causes of failure are burnout or vaporization of the tungsten filament.

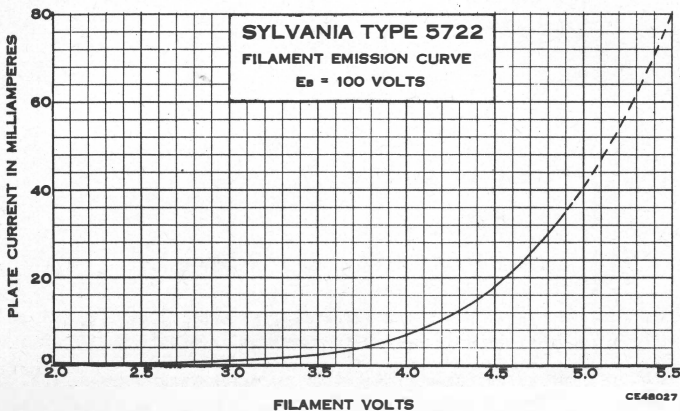

5722 (Cont'd)

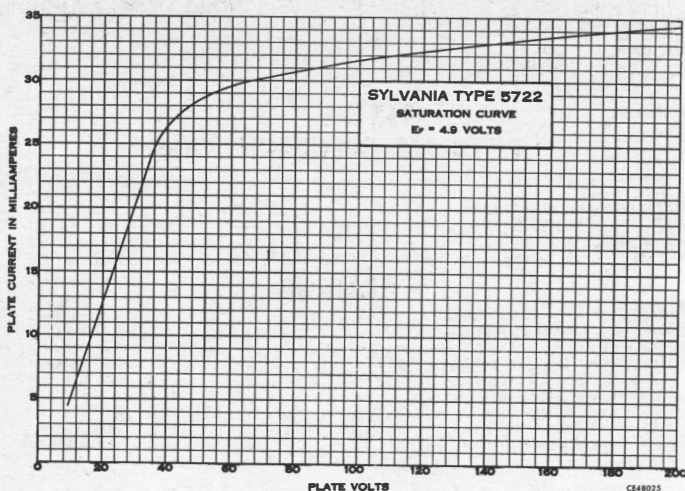

RECOMMENDED CIRCUIT

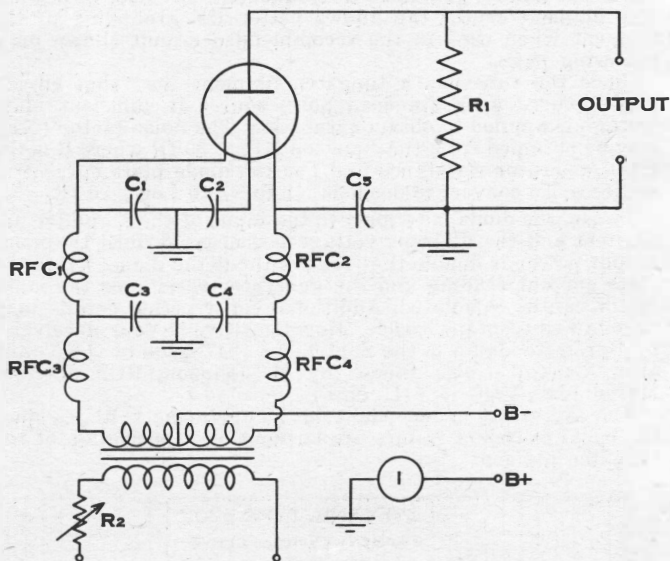

PARTS LIST

- | | |
|------------------|--|
| C ₁ | } 500 μ f |
| C ₂ | |
| C ₃ | |
| C ₄ | |
| C ₅ | |
| RFC ₁ | } 6 Turns #16 Enamel Wire on 3/16" Air Core |
| RFC ₂ | |
| RFC ₃ | } 30 Turns #16 Enamel Wire on 3/8" O.D., 1/4" I.D.
Bakelite Coil Form With Powdered Iron Core |
| RFC ₄ | |
| R ₁ | 50 to 300 Ohms as Required to Match Load |
| R ₂ | Filament Voltage Control |

SPECIAL PURPOSE TUBES—RECEIVING AND MISCELLANEOUS TYPES Cont'd

145 PENNSYLVANIA ELECTRONIC TUBES

TYPE	CONSTRUCTION			EMITTER			NOTES (1) (2) CAPACITIES IN $\mu\mu\text{f}$			USE	PLATE VOLTS	SCREEN VOLTS	NEG. VOLTS GRID	PLATE CUR- RENT MA	SCREEN CUR- RENT MA	PLATE RESIST- ANCE OHMS	AMP. μ FACTOR OR G_m μMHOS	OHMS LOAD FOR STATED POWER OUTPUT	POWER OUTPUT MW	
	CLASS	STYLE	BASE	TYPE	VOLTS	AMPS	C_{gp}	C_{in}	C_{out}											
7AK7	Pentode	Lock-In	8V	Cathode	6.3	0.8	0.7	12.0	9.5	Computer Tube	150 150 150	90 90 90	0 11 0	40 2.5m 2.0m	21 0.45 60m	11,500 ... $E_{c3}=9.5\text{ V}$	6,500	$E_{c3}=0\text{V}$ $E_{c3}=0\text{V}$	
12AY7	Special low noise audio amp. See complete data section.																			
25A7GT	Diode Pentode	T-9	8F	Cathode	25.0	0.30	H.W. Rectifier Power Amplifier	117 100	Volts per plate RMS, 75 Ma Output Current.			50,000	1,800	4,500	770		
26D6	Heptode	T-5½	7CH	Cathode	26.5	0.07	0.3	7.5	14.0	Converter	100	100	1.5	2.8	8.0	500,000 \downarrow	455 ∇	$R_{k1}=20,000$ $I_{c1}=0.5\text{ Ma}$ $R_{k1}=20,000$ $I_{c1}=0.5\text{ Ma}$ $R_{k1}=20,000$ $I_{c1}=0.1\text{ Ma}$		
											250	100	1.5	3.0	7.8	1.0 Meg. \downarrow	475 ∇			
											26.5	26.5	0.5	0.45	1.6	...	270 ∇			
28D7	Duo-Beam Amplifier	Lock-In	8BS	Cathode	28.0	0.40	Class A2 Amplifier	28	28	390 \blacktriangle $\%$	9.0 $\%$	0.7 $\%$	R-C Coupled P-P, R-C Coupled P-P Transformer Coupled	4,000 $\%$	80 $\%$		
											28	28	3.5	25.0	2.0		6,000 \downarrow	225		
											28	28	0	64.0	4.0		1,500 \downarrow	600		
28D7W (3)	Ruggedized version of Type 28D7. Data same as Type 28D7.																			
1222	Beam Pwr. Amp.	ST-14	1222	Cathode	6.3	0.9	Characteristics similar to Type 6L6GA.										
1229	Tetrode	ST-12	4K	Filament	2.0	0.06	Similar to Type 32. Electrometer tube (Low grid current).										
1273	Pentode	Lock-In	8V	Cathode	6.3	0.30	.004m	6.0	6.5	Amplifier	Characteristics same as Type 14C7 (Special Non-Microphonic Tube)									
1280	Pentode	Lock-In	8V	Cathode	12.6	0.15	.004m	6.0	6.5	Amplifier	Characteristics same as Type 14C7 (Special Non-Microphonic Tube)									
5654/ 6AK5W (3)	Pentode	T-5½	7BD	Cathode	6.3	0.175	0.02m	4.0	2.9	R F Amplifier	120	120	200 ∇	7.5	2.5	340,000	5,000	
5679	Duodiode	Lock-In	7CX	Cathode	6.3	0.15	Characteristics same as Type 7A6. For V.T.V.M. use.										
5722	Diode	T-5½	5CB	Filament	4.9	1.6	1.5	Noise Diode	150	...	For noise generator service $I_b=35\text{ Ma Max.}$							
5726/ 6AL5W (3)	Duodiode	T-5½	6BT	Cathode	6.3	0.3	Rectifier	117 A C volts per plate RMS, 9 Ma D C output current per plate.									

